

DETAILED SPECIFICATION FOR QCM SENSOR PART # QCM6140CrAu051-051-C

KEY FEATURES

- 6 MHz
- 14.0 MM SENSOR DIAMETER
- 5.1 / 5.1 MM ELECTRODE DIAMETER
- CHROMIUM / GOLD ELECTRODES
- 100% TESTED ELECTRICALLY AND VISUALLY

DESCRIPTION

For use in film thickness monitors. Very reliable function due to good adhesion of electrodes. Long operational life time. 180 degrees electrode flags for connection

GENERAL

Item	Parameter	Value
1.0	Sensor design	Plano-Plano
2.0	Angle of cut	AT
3.0	Jig compability	Custom

ELECTRICAL

4.1	Nominal frequency	6.000 MHz
4.2	Center frequency	5.990 MHz
4.3	Frequency tolerance	+/- 10 KHz
4.4	Q-value	> 100 000
4.5	Shunt capacitance, C0	Typ. 10 pF

ELECTRODES

5.1	Front electrode diameter	5.1 mm
5.2	Front electrode material	Cr/Au Chromium / Gold
5.3	Back electrode diameter	5.1 mm
5.4	Back electrode material	Cr/Au Chromium / Gold
5.5	One sided contacting	No

MECHANICAL & DRAWING

6.1	Nominal blank diameter	14.0 mm
6.2	Crystal axes orientation	Yes
6.3	Surface appearance	Transparent
6.4	Bevel	Yes



Quartz Crystal
Electrical equivalent 2pole

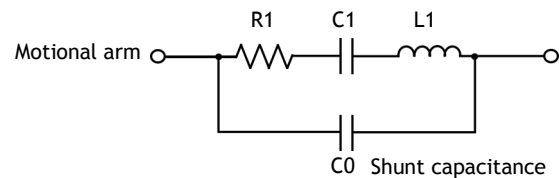

Front

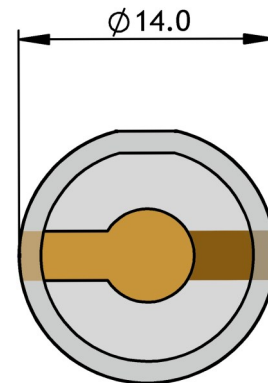

© 2013-2014 Quartz Pro
Image protected by Digimarc ®

Back

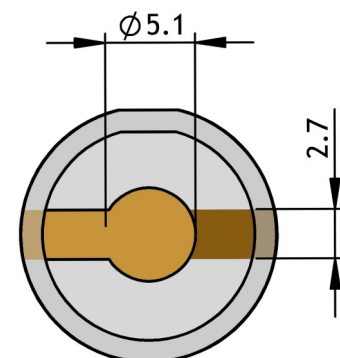

DETAILED SPECIFICATION FOR QCM SENSOR PART # QCM6140CrAu051-051-C

MARKING / LABEL

7.1	QR code	Simple info readout with QR app
7.2	Part Number	QCM6140CrAu051-051-C
7.3	Nom. Frequency	6.000 MHz
7.4	Sensor diameter	14.0 mm
7.5	Electrode material	Cr/Au Chromium / Gold



PACKAGING & STORAGE

8.1	Sensor package type	Revolving plastic depository with a transparent lid for easy inspection
8.2	Storage quantity	10 covered dust and shock protected storage positions and 1 open position for ejection
8.3	Package protection	Package is protected with a vacuum sealed plastic bag for prolonged storage and shipping
8.4	Storage recommendation	After opening plastic vacuum bag preferably store in dust free dry Air or Nitrogen @ room temperature.
8.5	Cleaning	No cleaning necessary before use. However after prolonged storage in humid air a light cleaning in a ultrasonic bath of either ultraclean water or alcohol without any denaturation can be done to remove adsorbed molecules on the surfaces

REVISION HISTORY

	Date	Description
9.0	2010.11.15	First issue
9.1	2014.08.15	New detailed datasheet
9.2		
9.3		
9.4		
9.5		

DETAILED SPECIFICATION FOR QCM SENSOR PART # QCM6140CrAu051-051-C

PRODUCT PART NUMBER DESIGNATION AND INTERPRETATION. FOR MORE ALTERNATIVES SEE PAGE 3

Item	Product Category	1. Nominal Frequency	2. Sensor Diameter	3a. Coating Multiple layer 3b. Coating Single layer	4. Electrode Diameter Ø Front-Back	5. Jig/Holder Compability
Parameter	QCM	6 MHz	14.0	Chrome/Gold	5.1.-5.1mm	Custom
Code	QCM	6	140	CrAu	051-051	C

Part number designation : QCM6140CrAu051-051-C

PART NUMBER DESIGNATION OPTIONS (AVAILABLE TYPES)

1. Nom Frequency	Designation	2. Sensor Diameter Ø	Designation	3a. Coating -Multiple layer	Designation
5.00 MHz	5	8.90 mm	089	Chromium/Gold	CrAu
6.00 MHz	6	12.45 mm	125	Silver/Aluminum	AgAl
9.00 MHz	9	14.0 mm	140	Nickel/Silver	NiAg
10.7 MHz	10	25.4 mm	254	Titanium/Gold	TiAu
				Chromium/Gold/SiO2	CrAuSiO2
				Nickel/Silver	NiAg

4. Electrode Diameter Ø Front-Back	Designation	5. Jig/Holder Compability	Designation	3b. Coating -Single layer	Designation
5.1-5.1 mm	051-051	Balzer	B	Gold	Au
5.4-5.4 mm	054-054	Sloan/Ulvac	S	Silver	Ag
7.5-5.0 mm	075-050	Inficon*	I	Copper	Cu
7.5-7.5 mm	075-075	Q Sense	Q	Titanium	Ti
11.5-11.5 mm	115-115	Maxtek 25.4 mm	M	Aluminum	Al
12.0-5.0 mm	120-050	HC-50	H		
12.8-6.4 mm	128-064	Custom	C		
13.0-6.4 mm	130-064				
13.0-13.0 mm	130-130				
13.3-6.0 mm	133-060				

* also compatible with Maxtek, Sycon, Sigma ,Intellimetrics, Fil-Tech, Phelps

Custom made products: In case you need something else that is not listed above, please feel free to ask and we will check our possibilities. Use our contact form under Contact. www.quartzpro.com

