

DETAILED SPECIFICATION FOR OCXO PART # OCXO10.0C33A211311B

KEY FEATURES

- f 10.000 MHz
- DIP 14 HERMETICALLY SEALED 20X13X11 MM PACKAGE
- 3.3 V SUPPLY VOLTAGE
- CMOS OUTPUT

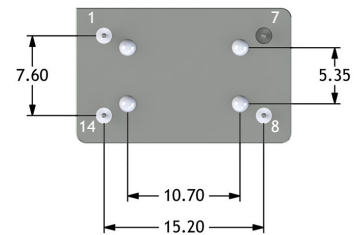
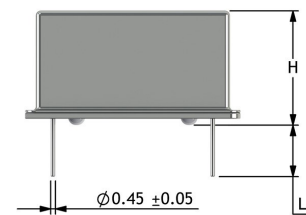
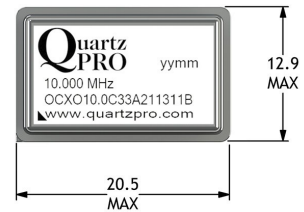

DESCRIPTION

Hermetically sealed for best environmental immunity. Miniature DIP 14. Wide temperature range. Fixed frequency output.

DETAILED SPECIFICATION ► ELECTRICAL

1. POWER SUPPLY CHARACTERISTICS (pin 14)

Item	Parameter	Condition	Min.	Typ.	Max.	Unit	Note
1.1	Supply voltage input		3.135	3.3	3.465	V	
1.2	Supply current at power on	at 25°C			1000 / 3.5	mA / W	
1.3	Supply current at steady state	at 25°C			200 / 0.7	mA / W	In still air 5 min after power on
1.4	Supply current at steady state	at Min T				mA / W	In still air 5 min after power on
1.5	Supply current at steady state	at Max T				mA / W	In still air 5 min after power on

2. CONTROL VOLTAGE INPUT

2.1	Transfer slope			Positive			
2.2	Input impedance					kohm	
2.3	Min frequency	@ Vc min				ppm	Vc min = 0V
2.4	Nom frequency	@ Vc nom				ppb	Vc nom = 1.65 V
2.5	Max frequency	@ Vc max				ppm	Vc max = 3.3 V
2.6	Tuning sensitivity					ppb/mV	
2.7	Tuning linearity					%	Deviation from a straight line fit

3. TEMPERATURE

			Min T	Max T	
3.1	Temperature range	operating	-30	+70	Deg C
3.2	Temperature range	storage	-55	+105	Deg C

DETAILED SPECIFICATION FOR OCXO PART # OCXO10.0C33A211311B

4A. OUTPUT SIGNAL FOR HCMOS, LVCMOS, CMOS (pin 8)

Item	Parameter	Condition	Min.	Typ.	Max.	Unit	Note
4.1	Load			15		pF	
4.2	Output Level	VOH / VOL	> 2.4		< 0.4	V	
4.3	Duty Cycle		45		55	%	
4.4	Rise / Fall time				< 5.0	ns	

4B. OUTPUT SIGNAL FOR SINEWAVE (pin 8)

4.5	Output Level	Sinewave				dBm	Load 50 ohm
4.6	Harmonics					dBc	
4.7	Non harmonics					dBc	

4.8 Short term stability Frequency domain, Phase Noise L(f)

4.8.1	Phase Noise @ offset frequency	1 Hz			-70	dBc / Hz	1 h after power on and still air
4.8.2	Phase Noise @ offset frequency	10 Hz			-100	dBc / Hz	1 h after power on and still air
4.8.3	Phase Noise @ offset frequency	100 Hz			-130	dBc / Hz	1 h after power on and still air
4.8.4	Phase Noise @ offset frequency	1KHz			-140	dBc / Hz	1 h after power on and still air
4.8.5	Phase Noise @ offset frequency	10KHz			-145	dBc / Hz	1 h after power on and still air
4.8.6	Phase Noise @ offset frequency	100KHz			-150	dBc / Hz	1 h after power on and still air

4.9 Short term stability Time domain, Allan Deviation sy(t)

4.9.1	Sample time (τ)	0,1s					1 h after power on and still air
4.9.2	Sample time (τ)	1.0s			< 1E ⁻¹⁰		1 h after power on and still air
4.9.3	Sample time (τ)	10s					1 h after power on and still air
4.9.4	Sample time (τ)	100s					1 h after power on and still air

5. FREQUENCY CHARACTERISTICS

5.1	Stability vs temperature	Min T/ Max T	-100		+100	ppb p-p	External Vc connected
5.2	Calibration accuracy	at 25°C and Vc nom	-500		+500	ppb	At delivery, 30 min after power ON
5.3	Frequency retrace *	15 min after Power On	-500		+500	ppb	Value 30 min after power ON compared to frequency prior to power OFF
5.4	Warm up time	at Vc Nom and 25°C			5	min	< ±500 ppb from final freq. after PO for
5.5	Long term stability (aging)	Per day	-3		+3	ppb	After 30 days of continues operation At 25°C
5.6	Long term stability (aging)	First year	-1000		+1000	ppb	After 30 days of continues operation At 25°C
5.7	Long term stability (aging)	After first year	-400		+400	ppb	After 30 days of continues operation At 25°C
5.8	Start up time	At 25°C and Vc nom				s	From power on to 67 % of V out
5.9	Load change	Cl ± 5%	-50		+50	ppb	
5.10	Vcc change	Vcc ± 5%	-50		+50	ppb	

* Retrace test precondition Power ON 24 h Power OFF 24 h and Vc nom and 25°C.

6A. REFERENCE VOLTAGE

6.1	Reference Voltage					V	
-----	-------------------	--	--	--	--	---	--

6B. OVEN ALARM

6.2	High level					V	Oven is ready (steady state)
6.3	Low level					V	Oven is warming up

DETAILED SPECIFICATION FOR OCXO PART # OCXO10.0C33A211311B

DETAILED SPECIFICATION ► ENVIRONMENTAL

7. VIBRATION IEC 60068-2-6 Fc

Line	Description	Parameter	Condition	Units	Notes
7.1	Type and frequency range	Sinewave 10 - 500 Hz			
7.2	Sweep parameters	Amplitude 10 - 55 Hz	0.75	mm	
7.3	Sweep parameters	Acceleration 55 - 500 Hz	10	g	
7.4	Sweep rate and direction	1 octave / minute = 6 minutes	up / down = 12	min	
7.5	Direction and number of sweeps	x,y and z	10		
7.6	Duration	6 min x 2 sweeps x 10 sweeps	120 x 3 = 360	min	
7.7	Type and frequency range	Sinewave 10 - 500 Hz			

8. SHOCK IEC 60068-27 Ea

8.1	Pulse waveform	Half sine	40 (peak)	g	
8.2	Puls length		11	ms	
8.3	Direction, sign and number of shocks	x,y and z	5 pos & 5 neg		In each 6 directions

9. TEMPERATURE CYCLING IEC 60068-2-14 Na

9.1	Low temperature		-40	Dec C	
9.2	High temperature		+85	Dec C	
9.3	Transition time		2 - 3	min	
9.4	Exposure time	Time in each temperature	10	min	
9.5	Number of cycles		5		

10. ADDITIONAL INFORMATION

10.1	Soldering	No clean solder and hand soldering recommended.			
10.2	Cleaning	Possible			
10.3	ESD	Parts are sensitive to Electro Static Discharge. Please use normal ESD precautions.			

DETAILED SPECIFICATION FOR OCXO PART # OCXO10.0C33A211311B

DETAILED SPECIFICATION ► MECHANICAL

11. LABEL MARKING

Frequency	in MHz
Part / Specification #	18 digits
Date code	2 last digits in Year (yy) and Week (ww) Example 0922 (Year 2009), (Week 22)
▲ Triangle in corner designates pin 1	

12. PIN / PAD ASSIGNMENT

Pin / Pad	Function	Assignment
1	NC	NC
7	Ground	Gnd
8	Output signal	Out
14	Supply Voltage	V _{cc}

13. MECHANICAL DIMENSIONS

Parameter	(mm)
H = Height	11.1 MAX
L = Pin length	5.5 ±0.5

14. REVISION HISTORY

	Date	Description
14.1	2013.05.10	First issue
14.2	2014.08.15	New detailed datasheet
14.3		
14.4		
14.5		
14.6		

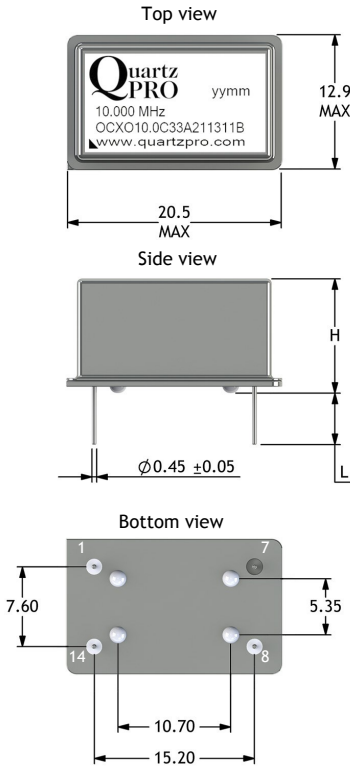

UNLESS OTHERWISE SPECIFIED :

TITLE OCXO211311H

	NAME	SIGN.	DATE	TOLERANCES	DWG NO.	OCXO211311H
DRAWN	Vikram Singh	VS	2013.05.07	MATERIAL A	REV.	0.1
CHK'D	Anders Aven	AA	2013.05.09	MATERIAL B		
APPV'D	Anders Olsen	AO	2009.05.09	WEIGHT GR		
NOTE						