

DETAILED SPECIFICATION FOR CRYSTAL PART # X50.000SC-43-M3-20AC



KEY FEATURES

- f 50.000 MHz
- COLD WELDED HC-43/U
- 3RD OVERTONE – HIGH Q VALUE
- SC CUT
- FOR OCXO APPLICATION

DESCRIPTION

Well documented / high performance Quartz Crystal with high Q value enabling low Phase Noise and low aging. For use in high performance and high reliability OCXO applications.

DETAILED SPECIFICATION ► ELECTRICAL

1. GENERAL

| Item | Parameter | Condition | Value | Tolerance | Unit | Note |
|------|-------------------------|---------------------|-------|-----------|------|-----------|
| 1.1 | Angle of cut | | SC | | | |
| 1.2 | Mode of operation | Overtone | 3rd | | | |
| 1.3 | Circuit type | Series resonance | | | | |
| 1.4a | Circuit type | Parallell resonance | | | | |
| 1.4b | Load capacitance, C_L | | 20 | +/- 1 | pF | |
| 1.5 | Drive level, nom P | Nominal P | 50 | +/- 10 % | uW | |
| 1.6 | Drive level, max P | Maximum P | 100 | +/- 10 % | uW | |
| 1.7 | Package | HC-43/U | | | | Height mm |

2. TEMPERATURE CHARACTERISTICS

| Item | Parameter | Condition | Min. | Typ. | Max. | Unit | Note |
|------|------------------------------|-----------|------|------|------|------|------|
| 2.1 | Reference temperature, ref T | | +81 | +89 | +97 | °C | |
| 2.2 | Operating temperature range | | | | | °C | |
| 2.3 | Storage temperature range | | -55 | | +105 | °C | |

3. ELECTRICAL PARAMETERS

| Item | Parameter | Condition | Min. | Typ. | Max. | Unit | Note |
|------|--------------------------|-----------|---------|---------|---------|------|-----------------------------|
| 3.1 | Motional resistance | R_1 | 30 | 40 | 50 | Ohm | |
| 3.2 | Motional inductance | L_1 | | 26 | | mH | |
| 3.2 | Motional capacitance | C_1 | 0.29 | 0.39 | 0.56 | fF | |
| 3.3 | Static shunt capacitance | C_0 | 3.5 | 4.1 | 4.6 | pF | |
| 3.4 | Figure of merit | Q | 150 000 | 200 000 | 250 000 | - | |
| 3.5 | Shunt inductance | L_0 | | 2.4 | | µH | Optional C_0 cancellation |

4. FREQUENCY CHARACTERISTICS

| Item | Parameter | Condition | Min. | Typ. | Max. | Unit | Note |
|------|----------------------------------|-------------------------------------|------|------------|------|------|--------------------------------------|
| 4.1 | Nominal frequency | @ ref T, C_L and nom P | | 50.000 000 | | MHz | |
| 4.2 | Frequency accuracy | @ ref T, C_L and nom P | -3.5 | | +3.5 | ppm | |
| 4.3 | Drive level dependency, $R_1(P)$ | $R_1 \text{ max} / R_1 \text{ min}$ | | | 10 | % | DLD sweep from 0.1 uW – nom P |
| 4.4 | Drive level dependency, $f_1(P)$ | $\Delta f / f \text{ nom}$ | | | | ppm | DLD Sweep from 0.1uW – nom P |
| 4.5 | Long term stability (aging) | First year | -200 | | +200 | ppb | After 30 days of continues operation |
| 4.6 | Long term stability (aging) | After first year | | | | ppb | After 30 days of continues operation |

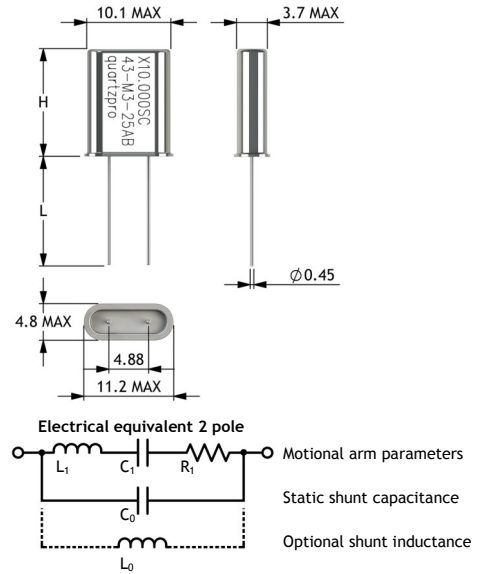

DETAILED SPECIFICATION FOR CRYSTAL PART # X50.000SC-43-M3-20AC

DETAILED SPECIFICATION ► ENVIRONMENTAL

5. VIBRATION IEC 60068-2-6 Fc (Sinewave)

| Item | Description | Parameter | Condition | Units | Notes |
|------|--------------------------------|------------------------------|--------------------|-------|----------------------------------------------|
| 5.1 | Frequency range | 10 - 55 Hz | Amplitude, 0.75 | mm | |
| 5.2 | Frequency range | 55 - 500 Hz | Acceleration, 10 | g | |
| 5.3 | Sweep rate and direction | 1 octave / minute | up / down = 11 | min | 5.5 octaves - 5.5 min / sweep*2 (1 up/1down) |
| 5.4 | Direction and number of sweeps | X, Y and Z | 10 sweeps | | |
| 5.5 | Duration | 5.5 min x 2 sweep x 10 sweep | 5.5 x 2 x 10 = 110 | min | ~ 1 hour 50 min |

6. SHOCK IEC 60068-2-27 Ea

| | | | | | |
|-----|--------------------------------------|----------------|-----------|----|-----------------------------------|
| 6.1 | Pulse waveform | Half sine | 40 (peak) | g | |
| 6.2 | Pulse length | | 11 | ms | |
| 6.3 | Sign, direction and number of shocks | +/- X, Y and Z | 5 | | In each direction, totally 5*6=30 |

7. TEMPERATURE CYCLING IEC 60068-2-14 Na

| | | | | | |
|-----|------------------|--------------------------|-------|-------|--|
| 7.1 | Low temperature | | -40 | Deg C | |
| 7.2 | High temperature | | +85 | Deg C | |
| 7.3 | Transition time | | 2 - 3 | min | |
| 7.4 | Exposure time | Time in each temperature | 10 | min | |
| 7.5 | Number of cycles | | 5 | | |

8. ADDITIONAL INFORMATION

| | | |
|-----|--------------|------------------------------------------------------------------------------------------------------------------------------------------|
| 8.1 | Wire cutting | Use a low shock wire cutter |
| 8.2 | Wire bending | Before bending of wires apply a flat plier at least 2 mm from glass insulation feedthrough and press so that the wire is strain relieved |
| 8.3 | Soldering | Use flux and a tip temperature of not more than 350 deg C and apply to crystal lead terminal for max 5 seconds. |
| 8.4 | Cleaning | If No Clean solder is used –not necessary to clean but recommended when flux is used. |
| 8.5 | ESD | Use normal ESD precautions. |
| 8.6 | Hermeticity | < 1·10 ⁻⁸ mbar liter / sec |

DETAILED SPECIFICATION FOR CRYSTAL PART # X50.000SC-43-M3-20AC

EXAMPLE OF PRODUCT PART NUMBER DESIGNATION AND INTERPRETATION.

| Item | Product Category | 1. Frequency | 2. Angle of cut | 3. Package | 4. Mode of operation | 5. Circuit type | 6. Version |
|-----------|------------------|--------------|-----------------|------------|----------------------|------------------------|------------|
| Parameter | X | 10.000 MHz | SC | HC-43/U | 3rd Overtone | Load Capacitance, 25pF | |
| Code | X | 10.000 | SC | - 43 | - M3 | - 25 | AB |

Part number designation : X10.000SC-43-M3-25AB

DETAILED SPECIFICATION ► MECHANICAL

9. LABEL MARKING

| | |
|------------------------------------------|---------------------------------------------------------|
| Line 1, Product Category, Frequency, Cut | in MHz - Cut Ex. X10.000SC |
| Line 2, Part number | Package - Mode - Circuit, Version Ex. 43 - M3 - 25AB |
| Other information on request. | |

10. MECHANICAL DIMENSIONS

| | (mm) |
|----------------|-----------|
| H = Height | 13.3 MAX |
| L = Pin length | 13.2 ±0.5 |

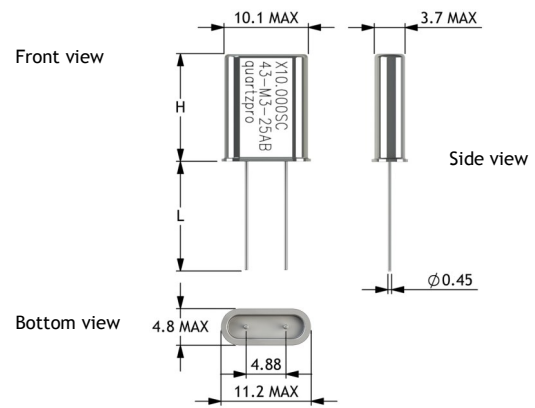

11. REVISION HISTORY

| | Date | Description |
|------|------------|------------------------|
| 11.1 | 2009.02.06 | First issue |
| 11.2 | 2014.08.15 | New detailed datasheet |
| 11.3 | | |
| 11.4 | | |
| 11.5 | | |
| 11.6 | | |

UNLESS OTHERWISE SPECIFIED :

TITLE X-HC-43-C

| | NAME | SIGN. | DATE | TOLERANCES | DWG NO. | X-HC-43-C |
|--------|--------------|-------|------------|------------|---------|-----------|
| DRAWN | Vikram Singh | VS | 2009.02.02 | MATERIAL A | REV. | 0.1 |
| CHK'D | Anders Aven | AA | 2009.02.03 | MATERIAL B | | |
| APPV'D | Anders Olsen | AO | 2009.02.03 | WEIGHT GR | | |
| NOTE | | | | | | |

SHEET 1 OF 1