

## DETAILED SPECIFICATION FOR CRYSTAL PART # X100.00AT-43-M5-20AC

### KEY FEATURES

- $f$  100.000 MHz
- COLD WELDED HC-43/U
- 5TH OVERTONE – HIGH Q VALUE
- AT CUT
- FOR OCXO APPLICATION

### DESCRIPTION

Well documented and cost effective Quartz Crystal for OCXO applications.

### DETAILED SPECIFICATION ► ELECTRICAL

#### 1. GENERAL

Item	Parameter	Condition	Value	Tolerance	Unit	Note
1.1	Angle of cut		AT			
1.2	Mode of operation	Overtone	5th			
1.3	Circuit type	Series resonance				
1.4a	Circuit type	Parallell resonance				
1.4b	Load capacitance, $C_L$		20	+/- 1	pF	
1.5	Drive level, nom P	Nominal P	50	+/- 10 %	uW	
1.6	Drive level, max P	Maximum P	100	+/- 10 %	uW	
1.7	Package	HC-43/U				Height mm

#### 2. TEMPERATURE CHARACTERISTICS

Item	Parameter	Condition	Min.	Typ.	Max.	Unit	Note
2.1	Reference temperature, ref T		+78	+84	+90	°C	
2.2	Operating temperature range					°C	
2.3	Storage temperature range		-55		+105	°C	

#### 3. ELECTRICAL PARAMETERS

Item	Parameter	Condition	Min.	Typ.	Max.	Unit	Note
3.1	Motional resistance	$R_1$	20	30	50	Ohm	
3.2	Motional inductance	$L_1$		4.1		mH	
3.2	Motional capacitance	$C_1$	0.52	0.62	0.75	fF	
3.3	Static shunt capacitance	$C_0$	3.8	4.1	4.6	pF	
3.4	Figure of merit	Q	65 000	95 000	110 000	-	
3.5	Shunt inductance	$L_0$		0.62		µH	Optional $C_0$ cancellation

#### 4. FREQUENCY CHARACTERISTICS

Item	Parameter	Condition	Min.	Typ.	Max.	Unit	Note
4.1	Nominal frequency	@ ref T, $C_L$ and nom P		100.000 000		MHz	
4.2	Frequency accuracy	@ ref T, $C_L$ and nom P	-5.0		+5.0	ppm	
4.3	Drive level dependency, $R_1(P)$	$R_1 \text{ max} / R_1 \text{ min}$			10	%	DLD sweep from 0.1 uW – nom P
4.4	Drive level dependency, $f_1(P)$	$\Delta f / f \text{ nom}$				ppm	DLD Sweep from 0.1uW – nom P
4.5	Long term stability (aging)	First year	-500		+500	ppb	After 30 days of continues operation
4.6	Long term stability (aging)	After first year				ppb	After 30 days of continues operation

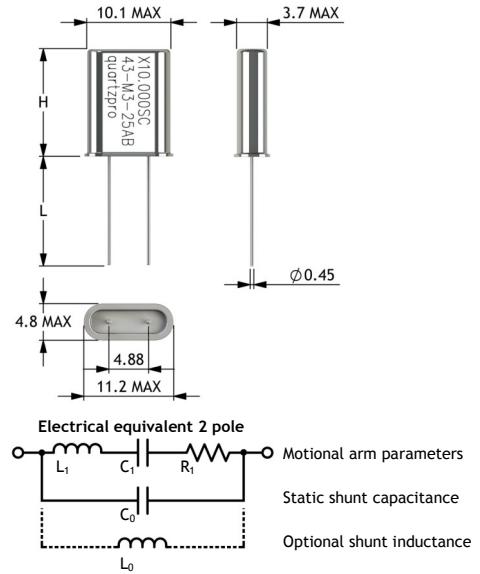

## DETAILED SPECIFICATION FOR CRYSTAL PART # X100.00AT-43-M5-20AC

### DETAILED SPECIFICATION ► ENVIRONMENTAL

#### 5. VIBRATION IEC 60068-2-6 Fc (Sinewave)

Item	Description	Parameter	Condition	Units	Notes
5.1	Frequency range	10 - 55 Hz	Amplitude, 0.75	mm	
5.2	Frequency range	55 - 500 Hz	Acceleration, 10	g	
5.3	Sweep rate and direction	1 octave / minute	up / down = 11	min	5.5 octaves - 5.5 min / sweep*2 (1 up/1down)
5.4	Direction and number of sweeps	X, Y and Z	10 sweeps		
5.5	Duration	5.5 min x 2 sweep x 10 sweep	5.5 x 2 x 10 = 110	min	- 1 hour 50 min

#### 6. SHOCK IEC 60068-2-27 Ea

6.1	Pulse waveform	Half sine	40 (peak)	g	
6.2	Pulse length		11	ms	
6.3	Sign, direction and number of shocks	+/- X, Y and Z	5		In each direction, totally 5*6=30

#### 7. TEMPERATURE CYCLING IEC 60068-2-14 Na

7.1	Low temperature		-40	Deg C	
7.2	High temperature		+85	Deg C	
7.3	Transition time		2 - 3	min	
7.4	Exposure time	Time in each temperature	10	min	
7.5	Number of cycles		5		

#### 8. ADDITIONAL INFORMATION

8.1	Wire cutting	Use a low shock wire cutter			
8.2	Wire bending	Before bending of wires apply a flat plier at least 2 mm from glass insulation feedthrough and press so that the			
8.3	Soldering	Use flux and a tip temperature of not more than 350 deg C and apply to crystal lead terminal for max 5 seconds.			
8.4	Cleaning	If No Clean solder is used –not necessary to clean but recommended when flux is used.			
8.5	ESD	Use normal ESD precautions.			
8.6	Hermeticity	< 1·10 <sup>-8</sup> mbar liter / sec			

## DETAILED SPECIFICATION FOR CRYSTAL PART # X100.00AT-43-M5-20AC

### EXAMPLE OF PRODUCT PART NUMBER DESIGNATION AND INTERPRETATION.

Item	Product Category	1. Frequency	2. Angle of cut	3. Package	4. Mode of operation	5. Circuit type	6. Version
Parameter	X	10.000 MHz	SC	HC-43/U	3rd Overtone	Load Capacitance, 25pF	
Code	X	10.000	SC	- 43	- M3	- 25	AB

Part number designation : X10.000SC-43-M3-25AB

## DETAILED SPECIFICATION ► MECHANICAL

### 9. LABEL MARKING

Line 1, Product Category, Frequency, Cut	in MHz - Cut Ex. X10.000SC
Line 2, Part number	Package - Mode - Circuit, Version
Other information on request.	

### 10. MECHANICAL DIMENSIONS

	(mm)
H = Height	13.3 MAX
L = Pin length	13.2 ±0.5

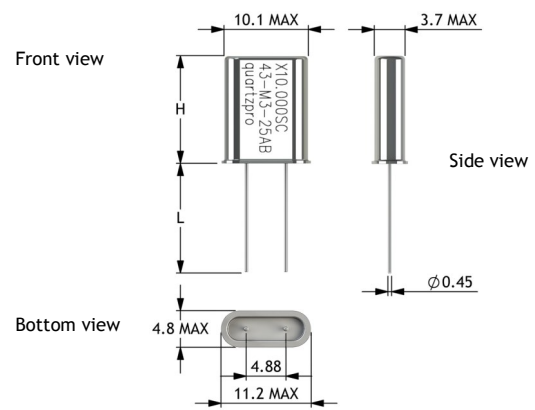

### 11. REVISION HISTORY

	Date	Description
11.1	2009.02.06	First issue
11.2	2014.08.15	New detailed datasheet
11.3		
11.4		
11.5		
11.6		

UNLESS OTHERWISE SPECIFIED :

TITLE X-HC-43-C

	NAME	SIGN.	DATE	TOLERANCES	DWG NO.	X-HC-43-C
DRAWN	Vikram Singh	VS	2009.02.02	MATERIAL A	REV.	0.1
CHK'D	Anders Aven	AA	2009.02.03	MATERIAL B		
APPV'D	Anders Olsen	AO	2009.02.03	WEIGHT GR		
NOTE						

SHEET 1 OF 1